

GCSE



WJEC GCSE in
DESIGN AND TECHNOLOGY

APPROVED BY QUALIFICATIONS WALES

**SAMPLE ASSESSMENT
MATERIALS**

Teaching from 2017



This Qualifications Wales regulated qualification is not available to centres in England.



For teaching from 2017
For award from 2019

GCSE DESIGN AND TECHNOLOGY
(ENGINEERING DESIGN)

SAMPLE ASSESSMENT
MATERIALS

Contents

	Page
UNIT 1: ENGINEERING DESIGN	
Question paper	5
Mark scheme	22

Candidate Name	Centre Number					Candidate Number				



GCSE DESIGN AND TECHNOLOGY

UNIT 1

ENGINEERING DESIGN

SAMPLE ASSESSMENT MATERIALS

2 hours

ADDITIONAL MATERIALS

In addition to this examination paper, you will need a calculator.

INSTRUCTIONS FOR CANDIDATES

Answer ALL questions.

Write your name, centre number and candidate number in spaces at the top of this page.

Write your answers in the spaces provided in this booklet.

Use black ink or black ball-point pen.

Do not use pencil or gel pen.

Do not use correction fluid.

INFORMATION FOR CANDIDATES

The number of marks is given in brackets at the end of each question or part question. You are advised to divide your time accordingly.

The total number of marks available is 100.

You are reminded of the need for good English and orderly, clear presentation in your answers. The quality of your written communication, including appropriate use of punctuation and grammar, will be assessed in your answer to question (4a).

1. The picture below shows the layout for a printed circuit board (PCB). It has been drawn using computer aided design (CAD).

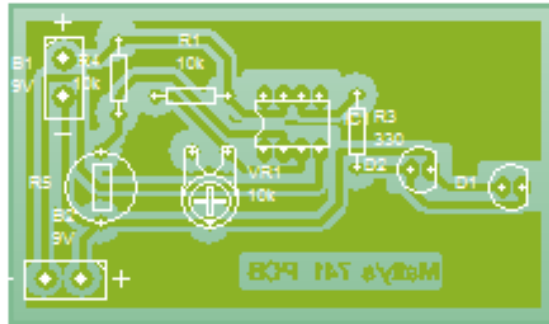

- (a) Explain **one** advantage of using CAD to produce the layout for the PCB. [2]

.....

.....

.....

- (b) Computer Numerical Control (CNC) machinery is often used to place components onto printed circuit boards (PCBs) when they are being produced in large quantities.

Describe **two** advantages of using CNC machinery for this purpose. 2 x [2]

Advantage 1:

.....

.....

Advantage 2:

.....

.....

- (c) Global manufacturing companies often design PCBs in one country and manufacture them in another.

Explain the ethical factors that these companies have to consider when choosing to manufacture in another country. [4]

.....

.....

.....

.....

.....

.....

2. The picture below shows a hydro-electric power station.



(a) Complete the sentence below.

The _____ energy of the stored water is converted into
_____ energy when the turbines rotate. [2]

(b) Explain one advantage and one disadvantage of building hydro-electric power stations. [4]

Advantage:
.....
.....

Disadvantage:
.....
.....

- (c) Electric hybrid bicycles, like the one shown below, use rechargeable lithium ion batteries.

Give **two** reasons why the use of lithium ion batteries, as a power source, creates environmental problems. [4]



Reason 1:

.....

.....

Reason 2:

.....

.....

3. The illustration below shows a model of a robotic arm. It uses a length of nitinol, and a smart material known as a shape memory alloy (SMA), to make the arm move. Both ends of the SMA are connected to a battery supply.

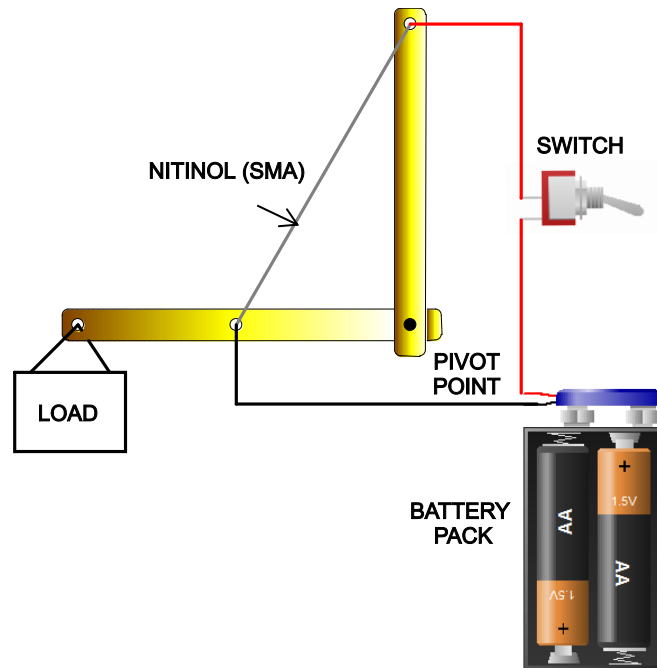

- (a) Explain what is meant by the term 'smart material'. [2]

.....

.....

.....

- (b) In the table below, number the statements in the correct order to explain what happens when the circuit is switched 'on' and then 'off'. [6]

Arm supporting the load will rotate upwards	
When switch in on position current will flow through the nitinol	
Nitinol will reduce in length/contract	
The load will bring the arm down to its original position	
When switch is in the off position current will not flow through the nitinol	
The nitinol will 'relax' and return to original length	

- (c) Smart materials have many applications.

- (i) Polymorph is a smart material.

Circle the correct statement below.

<p>Polymorph is a thermosetting plastic</p> <p>Polymorph is a thermoplastic</p>

[1]

- (ii) State an example of the use of a photochromic and thermochromic material. Write an explanation of the properties of each material. 2 x [3]

Photochromic use:

Explanation:

.....

.....

Thermochromic use:

Explanation:.....

.....

.....

4. The image below is of a hand held wind up torch. It has a crank handle that is turned when the torch needs charging up.



- (a) To test the ergonomics of the design, a model of the torch body and crank handle was made using 3D printing.
- (i) Explain one advantage and one disadvantage to the designer of 3D printing when rapid prototyping the models for the torch body. [4]

Advantage:

.....
.....

Disadvantage:

.....
.....
.....

5. (a) In the game shown below, the characters pop up and down and can be hit with a soft mallet.



- (i) Name a mechanism that could be used to make the characters pop up and down. [1]

Name of mechanism:

- (ii) In the space below, use annotated sketches of the mechanism named in (i) to make the characters pop up and down. [4]

- (b) You have been asked to make ten prototype mechanical games, for testing with potential users.

Explain in detail how you would make sure that the five holes in which the characters pop up and down are in exactly the same positions in all ten prototypes. [5]

.....

.....

.....

.....

.....

.....

.....

.....

.....

.....

- (c) The designer has specified thermoplastic as the main material for the game.

Evaluate why selection of a thermoplastic material for the pop up characters within the game has been influenced by functional and aesthetic factors. [5]

.....

.....

.....

.....

.....

.....

.....

.....

.....

.....

- (d) The game includes a control system so that a LED and buzzer switch on for 5 seconds when the soft mallet hits one of the characters.

Evaluate the benefits and potential problems of including this feature in the game. [5]

.....

.....

.....

.....

.....

.....

.....

.....

.....

.....

6. A manufacturer of washing machines is considering using quantum tunnelling composite (QTC) as part of a speed control system within the machine. A simple model is shown below.

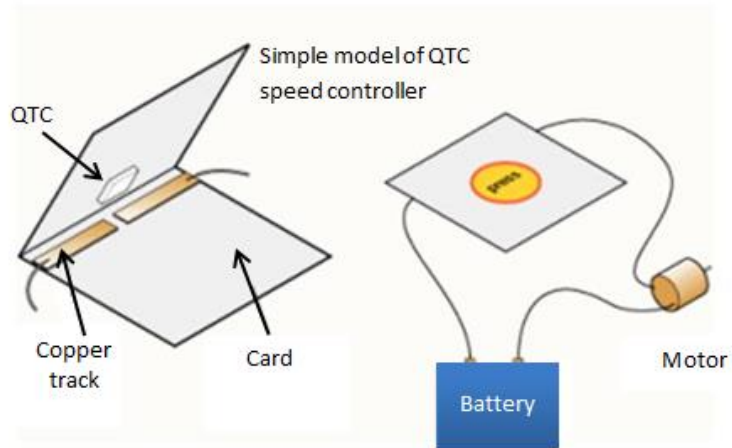

- (a) Explain what happens when the QTC is pressed. [2]

.....

.....

.....

- (b) The engineers and designers working on the prototype intend to connect the motor to the drum of the washing machine as shown below.

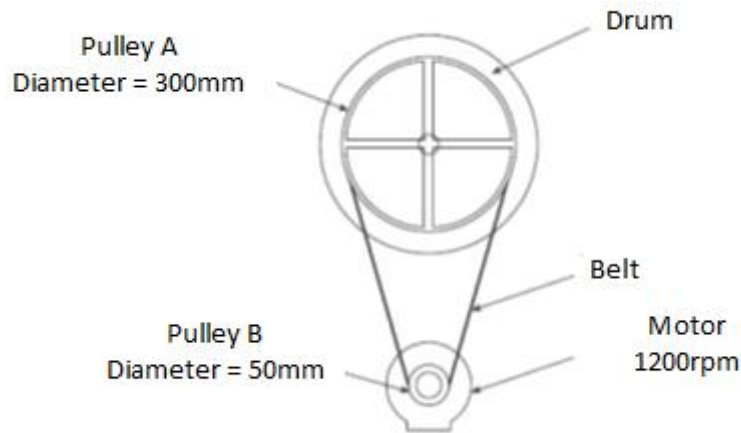

- (i) State whether pulley A or pulley B is the driver pulley to the system. [1]

Driver pulley is pulley :

- (ii) A toothed belt like the one shown is to be used in this pulley system.



Give **one** reason why a toothed belt is to be used in the pulley system. [2]

.....

.....

.....

- (iii) If the motor is turning at 1200rpm, calculate the speed of the drum. (Show all workings.) [3]

.....

.....

.....

.....

.....

- (c) (i) The design team intend to include a safety system so that the door of the washing machine stays locked in certain conditions. They have decided to use an OR gate in the control system.

Study the information below and complete the truth table. [3]

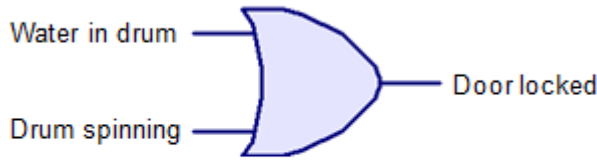

Water in drum	Drum spinning	Door locked
0	0	0
1	0	
	1	1
1		1

Water in drum (Yes = 1, No = 0)
 Drum spinning (Yes = 1, No = 0)
 Door locked (Yes = 1, No = 0)

- (ii) The design team wish to manufacture a prototype of the above system. A possible circuit diagram for the prototype is shown below. Study the diagram and complete the costings table for the required components. [6]

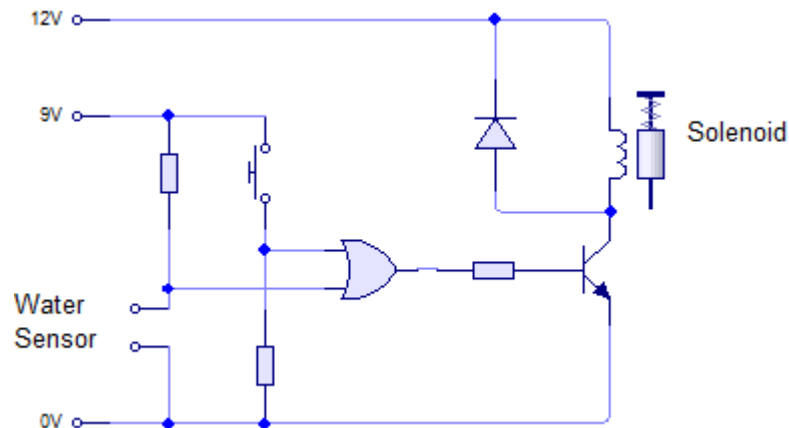

Component	Quantity	Cost (£)	Total
Resistor		0.05	
4072 Or gate		0.30	
Switch		0.40	
Water sensor		0.40	
Transistor		0.30	
Diode		0.05	
Solenoid		2.50	
		Total	

- (d) A scale model of the body of the washing machine is to be fabricated from a folded piece of sheet metal material such as aluminium or steel. The diagram below shows the shape of the development required to make the 3D model.

[8]

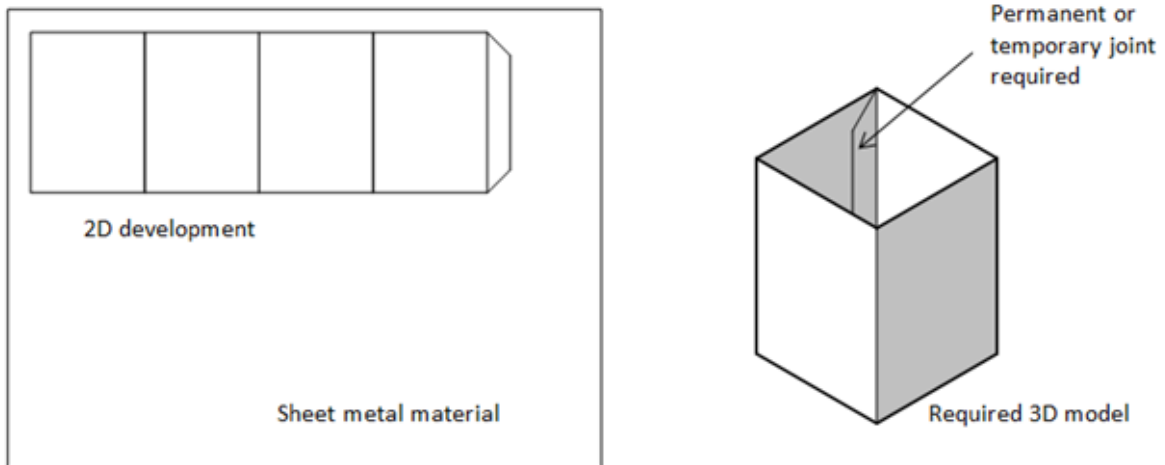

Using notes and sketches explain how the model would be manufactured from the sheet material. Include appropriate steps to achieve the desired 3D model, including named tools and machinery and details of your chosen joining technique.

MARK SCHEME

Guidance for examiners

Positive marking

It should be remembered that learners are writing under examination conditions and credit should be given for what the learner writes, rather than adopting the approach of penalising him/her for any omissions. It should be possible for a very good response to achieve full marks and a very poor one to achieve zero marks. Marks should not be deducted for a less than perfect answer if it satisfies the criteria of the mark scheme.

For questions that are objective or points-based the mark scheme should be applied precisely. Marks should be awarded as indicated and no further subdivision made.

Banded mark schemes

For band marked questions mark schemes are in two parts, the indicative content and the assessment grid.

The indicative content suggests the range of points and issues which may be included in the learner's answers. It can be used to assess the quality of the learner's response. Indicative content is **not** intended to be exhaustive and learners **do not** have to include all the indicative content to reach the highest level of the mark scheme.

In order to reach the highest level of the mark scheme a learner need not cover all of the points mentioned in the indicative content but must meet the requirements of the highest mark band. Where a response is not creditworthy, that is, it contains nothing of any significance to the mark scheme, or where no response has been provided, no marks should be awarded.

In Design and Technology, each question addresses one assessment objective: either AO3 or AO4. The assessment grid sub-divides the total mark to allocate for a question. These are shown in bands in the mark scheme. For each question, descriptors will indicate the different skills and qualities at the appropriate level.

Examiners should first read and place a tick in the learner's answer/s to indicate the evidence that is being assessed in that question; the mark scheme can then be applied. This is done as a two stage process.

Stage 1 – Deciding on the band

Beginning at the lowest band, examiners should look at the learner's answer and check whether it matches the descriptors for that band. If the descriptors at the lowest band are satisfied, examiners should move up to the next band and repeat this process for each band until the descriptors match the answer.

If an answer covers different aspects of different bands within the mark scheme, a 'best fit' approach should be adopted to decide on the band and then the learner's response should be used to decide on the mark within the band. For instance if a response is mainly in band 2 but with a limited amount of band 3 content, the answer would be placed in band 2, but the mark awarded would be close to the top of band 2 as a result of the band 3 content.

Examiners should not seek to mark learners down as a result of small omissions in minor areas of an answer.

Stage 2 – Deciding on the mark

During standardising (marking conference), detailed advice from the Principal Examiner on the qualities of each mark band will be given. Examiners will then receive examples of answers in each mark band that have been awarded a mark by the Principal Examiner. Examiners should mark the examples and compare their marks with those of the Principal Examiner.

When marking, examiners can use these examples to decide whether a learner's response is of a superior, inferior or comparable standard to the example. Examiners are reminded of the need to revisit the answer as they apply the mark scheme in order to confirm that the band and the mark allocated is appropriate to the response provided.

GCSE Design and Technology (Engineering Design)

MARK SCHEME

Question 1		AO3	AO4	Mark
(a)	Explain one advantage of using CAD to produce the layout for the PCB.		✓	2
	<p><i>Answers that indicate an understanding of CAD should be awarded up to 2 marks based on:</i></p> <p>Editing of CAD files. Storing files electronically so less physical space is required. Files being emailed to different locations/countries saving time and money. Simulation for quality control checking reducing faults and saving time and money</p> <p>Guidance to markers <i>Incorrect / no answer.</i> 0 marks <i>Brief description e.g. CAD files can be easily edited.</i> 1 mark <i>More detailed description e.g. CAD files can be easily edited which saves time/resources or CAD files can be emailed around the world saving time and money.</i> 2 marks</p>			
(b)	Computer Numerical Control (CNC) machinery is often used to place components onto printed circuit boards (PCBs) when they are being produced in large quantities. Describe two advantages of using CNC machinery for this purpose.		✓	4
	<p><i>Answers that indicate an understanding of using CNC machinery should be awarded up to 4 marks based on:</i></p> <p>CNC machines once programmed and maintained properly will run and run without any issues reducing costs i.e. no need for breaks just basic maintenance. Manual workers are prone to making mistakes/fatigue but CNC machinery is not. CNC are more accurate and quicker/consistent/for longer periods of time.</p> <p>Guidance to markers <i>Incorrect/no answer.</i> 0 marks <i>Brief description, very little detail e.g. CNC machines are more efficient/CNC machines don't make mistakes.</i> 1 mark <i>Description with some detail e.g. CNC machines are more efficient because they are not prone to human error/CNC machines can work 24/7 unlike manual workers.</i> 2 marks</p>			2 x 2

(c)	Global manufacturing companies often design PCBs in one country and manufacture them in another. Explain the ethical factors that these companies have to consider when choosing to manufacture in another country.		✓	4
<p><i>Answers that indicate an understanding of ethical factors in global production should be awarded up to 4 marks based on:</i></p> <p>Global manufacturers need to consider the welfare of workers in their overseas manufacturing facilities e.g. working conditions/hours/safe working practices. Global manufacturers need to consider the environmental impact of their facilities on the local area.</p> <p>Guidance to markers</p> <p><i>Incorrect/no answer.</i> 0 marks</p> <p><i>Brief explanation, very little detail e.g.</i> Ensure workers are not harmed. 1 mark</p> <p><i>Explanation, some detail e.g.</i> Ensure factories and equipment are safe for workers to use. 2 marks</p> <p><i>Explanation with detail e.g.</i> Ensure workers are treated properly and not following unsafe practices or working long hours/are trained correctly. Need to consider the impact of transportation over long distances. 3 marks</p> <p><i>Fully detailed explanation e.g.</i> Ensure working conditions are appropriate and that workers are properly trained and paid and that buildings/equipment/processes and working hours are safe. Need to consider the impact of transportation over long distances and the global footprint of the activity.</p>				
			Total	10

Question 2

Complete the sentence below.		AO3	AO4	Mark
(a)	The diagram shows a hydro-electric power station. The _____ energy of the stored water is converted into _____ energy when the turbines rotate.		✓	2
Guidance to markers <i>Incorrect / no answer.</i> Potential. Kinetic/electrical.				0 marks 1 mark 1 mark
(b)	Explain one advantage and one disadvantage of building hydro-electric power stations.		✓	4
<p><i>Answers that indicate an understanding of renewable energy and the advantage and disadvantage should be awarded up to 4 marks based on:</i></p> <p>A balanced answer that provides details of one advantage and one disadvantage.</p> <p>Advantages could be the energy supplier generating energy from a renewable source or the consumer receiving energy from a renewable source.</p> <p>An advantage could be the local community gaining because of increased visitors to the local area to view the HEP station.</p> <p>Disadvantages could be the local environment and natural habitats being disrupted/local community being disrupted.</p> <p>Guidance to markers</p> <p><i>Incorrect/no answer.</i> 0 marks</p> <p><i>Brief explanation, very little detail e.g. Advantage - the consumer receives the generated electricity or disadvantage - impact on the countryside.</i> 1 mark</p> <p><i>Explanation with some detail e.g. Advantage - the consumer receives the electricity from a renewable source or disadvantage - impact on the countryside as natural habitats might be destroyed.</i> 2 marks</p> <p><i>More detailed description of an appropriate method e.g. Advantage - the consumer receives the electricity from a renewable source and disadvantage - negative impact on the countryside.</i> 3 marks</p> <p><i>Fully detailed description of an appropriate method e.g. Advantage - the consumer receives the electricity from a renewable source and disadvantage - negative impact on countryside as natural habitats might be destroyed.</i> 4 marks</p>				

(c)	Electric hybrid bicycles, like the one shown below, use rechargeable lithium ion batteries. Give two reasons why the use of lithium ion batteries, as a power source, creates environmental problems.		✓	4
<p><i>Answers that indicate an understanding of the environmental problems of using lithium ion batteries should be awarded up to 4 marks based on:</i></p> <p>An understanding that lithium ion batteries contain toxic chemicals that could leach into the environment if not disposed of correctly and those rechargeable batteries still require electricity to charge them up and this may be from mains electricity produced from the burning of fossil fuels. Lithium is a finite resource and the mining of lithium can be dangerous and often occurs in developing countries.</p> <p>Guidance to markers</p> <p><i>Incorrect/no answer.</i> 0 marks</p> <p><i>Brief reason, very little detail e.g. Lithium is a toxic chemical.</i> 1 mark</p> <p><i>One reason, some detail e.g. Lithium is a toxic chemical and can be hazardous to the environment when disposed of.</i> 2 marks</p> <p><i>Two reasons with some detail e.g. Lithium is a toxic chemical and can be hazardous to the environment when disposed of and recharging the battery may require electricity from a non-renewable source.</i> 3 marks</p> <p><i>Fully detailed description of an appropriate method e.g. Lithium is a toxic chemical and can be hazardous to the environment when disposed and recharging the battery may require electricity from a non-renewable source using a fossil fuel causing pollution/carbon emissions.</i> 4 marks</p>				
Total				10

Question 3		AO3	AO4	Mark												
The illustration below shows a model of a robotic arm. It uses a length of nitinol, and a smart material known as a shape memory alloy (SMA), to make the arm move.....																
(a)	Explain what is meant by the term 'smart material'.		✓	2												
<p><i>Answers that indicate an understanding of smart materials should be awarded up to 2 marks based on:</i></p> <p>Smart material have properties that respond to changes in its surroundings/environment; its changes colour/appearance in response to external stimuli. Changes are reversible.</p> <p>Guidance to markers <i>Incorrect / no answer.</i> 0 marks <i>Brief description</i> 1 mark Can change shape/properties. <i>More detailed description</i> 2 marks Can change shape/properties when exposed to an external stimulus.</p>																
(b)	In the table below, number the statements in the correct order to explain what happens when the circuit is switched 'on' and then 'off'.		✓	6												
<table border="1" style="width: 100%; border-collapse: collapse;"> <tbody> <tr> <td style="padding: 5px;">Arm supporting the load will rotate upwards</td> <td style="text-align: center; width: 50px;">3</td> </tr> <tr> <td style="padding: 5px;">When switch in on position current will flow through the nitinol</td> <td style="text-align: center;">1</td> </tr> <tr> <td style="padding: 5px;">Nitinol will reduce in length/contract</td> <td style="text-align: center;">2</td> </tr> <tr> <td style="padding: 5px;">The load will bring the arm down to its original position</td> <td style="text-align: center;">6</td> </tr> <tr> <td style="padding: 5px;">When switch is in the off position current will not flow through the nitinol</td> <td style="text-align: center;">4</td> </tr> <tr> <td style="padding: 5px;">The nitinol will 'relax' and return to original length</td> <td style="text-align: center;">5</td> </tr> </tbody> </table>		Arm supporting the load will rotate upwards	3	When switch in on position current will flow through the nitinol	1	Nitinol will reduce in length/contract	2	The load will bring the arm down to its original position	6	When switch is in the off position current will not flow through the nitinol	4	The nitinol will 'relax' and return to original length	5			
Arm supporting the load will rotate upwards	3															
When switch in on position current will flow through the nitinol	1															
Nitinol will reduce in length/contract	2															
The load will bring the arm down to its original position	6															
When switch is in the off position current will not flow through the nitinol	4															
The nitinol will 'relax' and return to original length	5															
(c)(i)	Circled answer should be - Polymorph is a thermoplastic			1												
(c)(ii)	State an example of the use of a photochromic and thermochromic material. Write an explanation of the properties of each material.		✓	6												
<p><i>1 mark for each use and 2 marks for each explanation.</i></p> <p>Examples - security markers used to provide invisible identifiable marks on product which can be viewed under UV light. Technical understanding: Photochromic – changes colour in response to changes in light conditions Examples - temperature indicators for fish tanks/forehead thermometers. Technical understanding: Thermochromic– changes colour in response to changes in temperature</p> <p>Guidance to markers <i>Incorrect/no answer.</i> 0 marks <i>Brief description with little detail e.g.</i> Thermochromic materials change colour. 1 mark <i>More detailed description e.g.</i> Thermochromic material will go through a range of colours depending on temperature. 2 marks <i>Accept any appropriate answers for photochromic.</i></p>																
Total				15												

Question 4		AO3	AO4	Mark
The image below is of a hand held wind up torch. It has a crank handle that is turned when the torch needs charging up.				
(a)(i)	Explain one advantage and one disadvantage to the designer of 3D printing when rapid prototyping the models for the torch body.		✓	4
<p><i>Answers that indicate an understanding of the advantages and disadvantages of 3D printing should be awarded up to 4 marks based on: Candidates are required to write an advantage and disadvantage of 3D printing.</i></p> <p>Advantage 3D printing allows the designer to realise a physical idea quickly from a CAD drawing. This prototype can then be tested and modifications identified.</p> <p>Disadvantage The greatest disadvantage of 3D printers is the cost of manufacturing a high quality outcome. The higher the quality outcome the higher the cost of the machine. The quality of the finish can leave a lot to be desired in a 3D printed object. It isn't only the lack of polish that is the problem but also the possible dimensional inaccuracy.</p> <p>Guidance to markers</p>				
No answer or no relevant information presented or discussed.				0
<p>Brief description for example 3D printing provides an accurate outcome of a CAD drawing of the torch body.</p> <p>3D printing the body of the torch would be very costly.</p>				1
<p>More detailed response 3D printing produces a physical model of a CAD idea very quickly for testing, ideal for the torch body.</p> <p>3D printing is very costly and the finished quality at present is not up to other manufacturing methods.</p>				2
(a)(ii)	The production version of the crank handle is to be injection moulded. Describe the process of injection moulding the crank handle.		✓	6
<p><i>Answers that indicate an understanding of injection moulding should be awarded up to 6 marks based on:</i></p> <p>Plastic granules would be fed into a hopper. Archimedean spiral would feed the granules past the heating element. The heating element would fuse the granules together. The Archimedean spiral now has the effect of injecting the semi-liquid plastic into the crank handle mould. The mould will cool the semi-liquid plastic and the resulting crank handle will be formed. The mould would then be split open and the crank handle removed.</p> <p>Guidance to markers Accept the stages in the process above, up to a total of 6 marks. You may award 1 mark for each appropriate stage identified. Accept stages out of order.</p>				

(b)	Analyse how anthropometric data would have been used by the designer and how the designer has addressed the important issue of ergonomics.	✓		10
<p><i>Answers that indicate an understanding of anthropometrics and ergonomics should be awarded up to 10 marks based on:</i></p> <p>Knowledge and understanding that anthropometrics is based on average human measurements to give standard sizes; it allows designers to develop products that fit as intended and allow for the products to be used/held/carried comfortably and are fit for purpose.</p> <p>Candidates could discuss the following points:</p> <p><i>Anthropometric size:</i></p> <p>Hand size when gripping. Finger sizes for changing components, bulbs etc. Grip size for the wind-up mechanism. Deciding upon male/female user (age young/old) could have an effect. Wrist size. Considering the 5th to 95th percentile of the typical target market. Biomechanics and the typical force required to turn the crank handle and whether this will cause fatigue.</p> <p><i>Ergonomic factors:</i></p> <p>Weight of the torch and whether this is suitable to carry for the target market. Shape of the torch so it is comfortable to hold. Shape of the handle so that it is easy to grip when turning Feel – is it soft/rough to the touch and could texture cause discomfort whilst in use. Ease of grip in wet and dry conditions. Aesthetics – how the ergonomic shape/form and choice of material affect the style and appearance of the wind-up torch. Accessibility of being able to change batteries.</p>				
Guidance to markers				
Incorrect/no answer.				0
<p>Brief analysis with little detail of anthropometric data or ergonomic issues. Quality of Written Communication is limited, presenting material with limited coherence, many errors of grammar, punctuation and spelling. e.g. The designer will collect data relating to hand measurements. Data like grip size to determine the correct shape of the torch body which allows the user to hold the torch comfortably.</p>				1 - 2
<p>More detailed analysis, with some explanation of required anthropometric data and ergonomic issues. Quality of Written Communication is basic, presenting occasionally appropriate material with some coherence, some errors of grammar, punctuation and spelling. e.g. The designer will collect data relating to hand measurements. Data like grip size and finger width to determine the correct size and shape of the torch body/crank handle shape which allows the user to hold and grip the torch comfortably and turn the crank handle. Weight of the torch also needs to be considered as the torch is a portable device.</p>				3 - 4

<p>Detailed analysis and explanation of the types of anthropometric data required and relevant ergonomic issue evident.</p> <p>Quality of Written Communication is good, presenting mainly appropriate material in a coherent manner, few errors of grammar, punctuation and spelling.</p> <p>e.g. The designer will collect data relating to hand measurements relating to the chosen target market and age ranges within that target market. Data like grip size and force of grip/finger width to determine the correct size and shape of the torch body/crank handle shape and length which allows the user to hold and grip the torch comfortably and turn the crank handle in dry and wet conditions. Weight of the torch also needs to be considered as the torch is a portable device.</p>	<p>5 - 7</p>
<p>Clear and detailed analysis and explanation of the types of anthropometric data required and relevant ergonomic issues evident.</p> <p>Quality of Written Communication is excellent, presenting wholly appropriate material in a coherent and logical manner, hardly any errors of grammar, punctuation and spelling.</p> <p>e.g. The designer will collect data relating to hand measurements relating to the 5th to 95th percentile of the chosen target market and age ranges within that target market. Biomechanics and fatigue will also be considered. Data, like grip size and force of grip, finger width and torque is used to determine the correct size and shape of the torch body and crank handle shape and length which allows the user to hold and grip the torch comfortably and turn the crank handle with the required force in dry and wet conditions. Weight of the torch also needs to be considered as the torch is a portable device and may need to be carried for prolonged periods. Ease of removing components to aid maintenance and related anthropometric data and ergonomic issues will also need to be considered.</p>	<p>8 -10</p>
<p>Total</p>	<p>20</p>

Question 5				
In the game shown below, the characters pop up and down and can be hit with a soft mallet.		A03	A04	Mark
(a)(i)	Name a mechanism that could be used to make the characters pop up and down.		✓	1
	Candidates should be awarded 1 mark for naming an appropriate mechanism. Accept any appropriate mechanism e.g. cranked spindle, cam-shaft etc.			
(ii)	In the space below, use annotated sketches of the mechanism named in (i) to make the characters pop up and down.		✓	4
	<p>Marks should be awarded for: Terms and quality of sketches showing how the mechanism works <i>Candidates can be awarded a mark for a sketch without detail and up to two marks for a description of the mechanism without a sketch.</i></p> <p>Guidance to markers <i>Incorrect/no answer. 0 marks</i> <i>Sketch with very little detail 1 mark</i> <i>Sketch with some detail 2 marks</i> <i>Sketch with detailed descriptions 3 marks</i> <i>Sketch with fully detailed descriptions 4 marks</i></p>			
(b)	Explain in detail how you would make sure that the five holes in which the characters pop up and down are in exactly the same positions in all ten prototypes.		✓	5
	<p>1 mark can be awarded to the candidate for their understanding for the need of marking out the holes only. To achieve a full answer equivalent to five marks we would expect the candidates to discuss the making and manufacture of a jig/template. We are looking for an explanation of how to make the jig and use it. You may award 1 mark for each appropriate response.</p> <p>Guidance to markers <i>Incorrect/no answer. 0 marks</i> <i>For mentioning a jig/template. 1 mark</i> <i>For indicating a datum edge or point on the jig/template. 2 marks</i> <i>For indicating a datum edge or point on the jig/template and marking out the hole positions accurately on the template. 3 marks</i> <i>For indicating a datum edge or point on the jig/template and marking out the hole positions accurately on the jig/template and drilling 5 holes with a pilot drill 4 marks</i> <i>For indicating a datum edge or point on the jig/template and marking out the hole positions accurately on the jig/template and drilling 5 holes with a pilot drill. The template would be aligned to each subsequent prototype and accurately indicate the positions of the holes for all ten. 5 marks</i></p>			

(c)	Evaluate why selection of a thermoplastic material for the pop up characters within the game has been influenced by functional and aesthetic factors.	✓		5
<p><i>Candidate's response will need to address the selection of a plastic material for the mechanical game in terms of functional and aesthetic factors:</i></p> <p>Functional Electrical resistance/insulator Hardwearing Shock resistance/toughness Aesthetics Plastic is available in a range of colours - contrasting colours. Complex forms/shapes and styling can be achieved (characters within the game). Decorative features or functional textures can be easily achieved</p> <p>Guidance to markers</p> <p>No answer or no evaluation. 0 marks</p> <p>Simplistic evaluation but no reasoning Limited understanding evident. 1 mark The pop up characters are made from plastic because it is hardwearing.</p> <p>Some evaluation evident and limited reasoning. Some understanding evident. 2-3 marks The body of the pop up characters are plastic because it has hardwearing qualities to withstand repeated blows of the soft hammer mallet. The shape of the characters within the game can be easily achieved because the plastic is able to be moulded.</p> <p>Clear evaluations with detailed reasoning. Detailed understanding evident. 4-5 marks The body of the pop up characters are plastic because it has hardwearing qualities and will need to last. The plastic will also need to be tough and be able to withstand the repeated soft hammer mallets impact. The shape of the characters within the game can be easily achieved because the plastic is able to be moulded and the main details are able to be formed with finer details also surface able to be painted on.</p>				

(d)	Evaluate the benefits and potential problems of including this feature in the game.	✓		5
<p><i>Candidate's response will need to address the addition of a control system that has an LED and buzzer switching on for 5 seconds.</i></p> <p>Benefits Could bring more enjoyment to the game. The flashing LED lights and sounds will attract more customers to the game and hopefully more profit.</p> <p>Potential problems More components/parts will increase the final manufactured cost. Electronic devices do not like vibrations or sudden impacts. Replacement parts- circuit boards.</p> <p>The addition of a LED and buzzer which switches on for 5 seconds could attract new customers to the game and increase the profits for the owner.</p>				

	<p>Guidance to markers</p> <p>No answer or no evaluation. 0 marks</p> <p>Simplistic evaluation but no reasoning Limited understanding evident. 1 mark The addition of a LED and buzzer which switches on for 5 seconds could attract new customers to the game. Some evaluation evident and limited reasoning.</p> <p>Some understanding evident. 2-3 marks The addition of a LED and buzzer which switches on for 5 seconds could attract new customers to the game and increase the profits for the owner. With the additional components, there is an obvious additional cost to including these in the system.</p> <p>Clear evaluations with detailed reasoning. Detailed understanding evident. 4-5 marks The addition of a LED and buzzer which switches on for 5 seconds could attract new customers to the game and increase the profits for the owner. With the additional components, there is an obvious additional cost to including these in the system. Also, systems do not like vibrations or sudden impacts and this could affect the quality and durability of the game.</p>	
	Total	20

Question 6		AO3	AO4	Mark
A manufacturer of washing machines is considering using quantum tunnelling composite (QTC) as part of a speed control system within the machine. A simple model is shown below.				
(a)	Explain what happens when the QTC is pressed.		✓	2
<p><i>Answers that indicate an understanding of QTC should be awarded up to 2 marks based on:</i> QTC being similar to a variable resistor and that its resistance will fall when a force is exerted on it. In this simple model the motor will turn faster when the QTC is pressed.</p> <p>Guidance to markers <i>Incorrect / no answer.</i> 0 marks <i>Brief description e.g. The motor comes on.</i> 1 mark <i>More detailed description e.g. The motor comes on and as more force is exerted on the QTC the motor will turn faster.</i> 2 marks</p>				
(b)(i)	State whether pulley A or pulley B is the driver pulley to the system		✓	1
<p>Guidance to markers <i>Incorrect / no answer.</i> 0 marks Pulley B. 1 mark</p>				
(b)(ii)	Give one reason why a toothed belt is to be used in the pulley system.		✓	2
<p><i>Answers that indicate an understanding of a toothed belt should be awarded up to 2 marks based on:</i> The toothed belt will reduce slip as it meshes with the toothed pulley wheel. This will also allow for more precise and efficient transfer of motion.</p> <p>Guidance to markers <i>Incorrect / no answer.</i> 0 marks <i>Brief reason e.g. so that it doesn't slip.</i> 1 mark <i>More detailed reason e.g. so that it doesn't slip so the transfer of motion is more precise/efficient.</i> 2 marks</p>				
(b)(iii)	If the motor is turning at 1200rpm, calculate the speed of the drum.		✓	3
<p><i>Answers that indicate an understanding of the pulley speeds should be awarded up to 3 marks based on:</i> Workings that clearly show an understanding of how to calculate the speed of the drum using the input speed of 1200rpm and the diameters of the two pulleys. Workings must be evident. Final answer must include rpm.</p> <p>Guidance to markers <i>Incorrect/no answer</i> 0 marks 300/50 = 6. 1 mark 1200/6 = 200. 1 mark 200rpm 1 mark</p>				

(c)(i)	<p>The design team intend to include a safety system so that the door of the washing machine stays locked in certain conditions. They have decided to use an OR gate in the control system. Study the information below and complete the truth table.</p>		✓																
<p><i>Answers that indicate an understanding of an OR gate should be awarded up to 3 marks based on:</i> Indicating that the missing input/output signals would be indicated with a 1 in the truth table.</p> <p>Guidance to markers</p> <p><i>Incorrect/no answer. 0 marks</i></p> <table border="1" data-bbox="448 696 979 904" style="margin-left: auto; margin-right: auto;"> <thead> <tr> <th>Water in drum</th> <th>Drum spinning</th> <th>Door locked</th> </tr> </thead> <tbody> <tr> <td style="text-align: center;">0</td> <td style="text-align: center;">0</td> <td style="text-align: center;">0</td> </tr> <tr> <td style="text-align: center;">1</td> <td style="text-align: center;">0</td> <td style="text-align: center;">1</td> </tr> <tr> <td style="text-align: center;">1</td> <td style="text-align: center;">1</td> <td style="text-align: center;">1</td> </tr> <tr> <td style="text-align: center;">1</td> <td style="text-align: center;">1</td> <td style="text-align: center;">1</td> </tr> </tbody> </table> <p style="text-align: right;">1 mark 1 mark 1 mark</p>					Water in drum	Drum spinning	Door locked	0	0	0	1	0	1	1	1	1	1	1	1
Water in drum	Drum spinning	Door locked																	
0	0	0																	
1	0	1																	
1	1	1																	
1	1	1																	
(c)(ii)	<p>The design team wish to manufacture a prototype of the above system. A possible circuit diagram for the prototype is shown below. Study the diagram and complete the costings table for the required components.</p>		✓	6															
<p><i>Answers that indicate an understanding of circuit boards and components should be awarded up to 6 marks based on:</i> Using the PCB layout and correctly identifying the correct quantities of components including the 3 resistors. Using these quantities to correctly calculating the correct totals for each row and the total amount of £4.10 for all components needed for the PCB.</p> <p>Guidance to markers</p> <p><i>Incorrect/no answer. 0 marks</i> Some correct quantities. 1 mark Correct quantities including 3 x resistors. 2 marks Some correct individual component totals including 15p for resistors. 3 marks Correct individual component totals including 15p for resistors. 4 marks Correct total of 410 or 4.10. 5 marks Correct total with units e.g. 410p or £4.10. 6 marks</p>																			

(d)	Using notes and sketches explain how the model would be manufactured from the sheet material. Include appropriate steps to achieve the desired 3D model, including named tools and machinery and details of your chosen joining technique.		✓	8
<p><i>Answers that indicate an understanding of 3D modelling should be awarded up to 8 marks based on:</i></p> <p>The stages of marking out, cutting, shaping and joining sheet material. Look for a suitable marking out procedure (permanent marker/scraper/ruler etc.) Look for a suitable cutting out procedure and drilling if required (tin snips/shears/bandsaw/guillotine or CNC cutting e.g. milling or routing would be acceptable). Look for heat treatment like annealing to soften the sheet material prior to bending over some kind of former/using a bending machine/bending bars. Look for a suitable permanent or temporary fixing method e.g. pop rivets/nut and bolt/brazing/welding/epoxy resin.</p> <p>Guidance to markers</p> <p><i>Incorrect/no answer.</i> 0 marks</p> <p><i>Brief description with little detail e.g.</i> The development is marked out, cut and bent into shape. 1 - 2 marks</p> <p><i>More detailed description e.g.</i> The development is marked out using a scriber and a ruler (or other suitable marking out technique) and cut to shape using a pair of tin snips/shears/guillotine/metal-cutting band saw and then bent to shape. 3 - 4 marks</p> <p><i>Detailed descriptions e.g.</i> The development is marked out using a scriber and a ruler (or other suitable marking out technique) and cut to shape using a pair of tin snips/shears/guillotine/metal-cutting band saw/cnc. Holes are marked out and drilled in the tab. The shape is bent and formed over a former/or bending machine/or bending bars. The ends are joined by rivets/nut and bolts/brazing (if steel). 5 - 6 marks</p> <p><i>Fully detailed description e.g.</i> The development is marked out using a scriber and a ruler (or other suitable marking out technique) and cut to shape using a pair of tin snips/shears/guillotine/metal-cutting band saw. Holes are marked out and drilled in the tab. Metal is annealed to soften and make metal more malleable. The shape is bent and formed over a former/in a vice/or using a bending machine/or bending bars. The ends are joined by rivets/nut and bolts/brazing (if steel). 7 - 8 marks</p>				
			Total	25